

Winterwarm Agri 2024



Winterwarm heating solutions

Looking for an efficient heater for your glass house or your poultry house?

Winterwarm offers various heating solutions for this purpose.

Winterwarm-quality

- More than 85 years of experience
- ISO 9001-2015 certified
- Quick delivery
- Reliable



About us

Winterwarm, quality all over
page 3



DHX heater

Direct gas fired heater
for poultry houses, glass houses
and pigsties
page 12 / 13



DX-EH heater

Electric heater, specifically for
sustainable heating of stables
page 4 / 5



DXB heater

Direct oil fired heater
for poultry houses
page 12 / 14



DXC heater

An indirect gas fired heater
with a closed combustion
system, especially designed
for inside poultry houses
page 6 / 9



DX Fan

For optimal air distribution
in poultry houses or glass
houses
page 15



DXE heater

An indirect gas fired heater
with a closed combustion
system, for installation
outside the poultry house
page 10 / 11



*Jevansa Poultry - Erp (NL)
3 poultry houses with each 4 DXC
heaters for in total 120.000 chickens.*

Winterwarm World Wide



Introduction

For more than 87 years now, Winterwarm has been engaged in the development, production and sales of heating systems for the industrial, agricultural and retail markets. We achieved a leading position in the European market by focusing on three things: quality, service and innovation.

For the agricultural market we have developed a wide range of different types of heaters for poultry houses, greenhouses and pigsties suitable for different types of energy: electricity, gas and oil. Our heating systems are sold throughout the whole world.



In our new, sustainably built factory we have our own R&D department whose engineers develop new products and improve existing ones. Our goal is to provide our customers with reliable products of high quality for a reasonable price. Also we are extending our program with more sustainable heating solutions. The quality of our product is secured on the one hand by the ISO 9001-2015 certification which is implemented throughout our whole organization and on the other hand by submitting each heater to an extensive final test before it leaves our factory.



Another focus of Winterwarm is to fully support our dealers in all countries. This comprises of giving advice on our selection of heaters, detailed order information and quick reaction to service requests. Additionally, our website provides clear information on our products and our webshop allows quick identification and delivery of service parts.

In short, Winterwarm is a successful international organization which is happy to provide the heating for your poultry house, glasshouse or pigsty.



DX-EH heaters

More and more barn roofs are filled with solar panels for sustainable electricity. To get the most out of your own power generation with solar panels, wind turbines or a windmill, Winterwarm has developed the DX-EH.

Electric heating system

The DX-EH is an electric air heater specifically for the sustainable heating of poultry and pig stables. Besides the use of "free" energy, electric heating also has a positive influence on the stable climate. No moisture or CO₂ is added which needs to be ventilated as with traditional gas heaters. The air humidity remains low and so do the ammonia emissions. This is also beneficial to animal health.

Safe and reliable

The DX-EH has a heating capacity of 40 kW. It can be applied to cover 100% of the heating requirement in a stable/poultry house, or in combination

with a gasfired DXC or DHX which are provided with the same controlling equipment. The unit's electronic components are housed in a splash-proof box, therefore cleaning with a high pressure hose is no problem. All DX-EH heaters are subject to a final test during which electrical safety, and general operation are checked.

Controls

The DX-EH is provided with an on/off contact for simple control. Also the heater can operate in high/low modus (100%-60%) by means of an Interface Unit. This unit can be connected to a climate control system. With a 0-10 V. signal current functions like burner modulation, ventilation, operation signal, failure signalization and remote reset can be controlled.

Next to the Interface Unit usually a Remote Status reader is installed to read out the various functions.



Remote Status Reader GD3202

On/off thermostat IP794209



Interface Unit - IB5902

- Zone control for 1-8 heaters
- 0-10 V. analogue input
- Connection for burner on/off
- Connection for ventilation on/off
- Reset function
- Output failure signal
- Output "in operation" signal

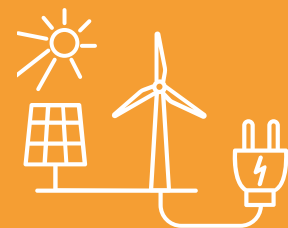

Characteristics:

- Sustainable heating
- Optimal use of own power generation
- Simple maintenance
- For use in poultry houses and pigsties
- High air output
- Low noise level
- 100% efficiency
- Splash waterproof
- Stainless steel casing

top view

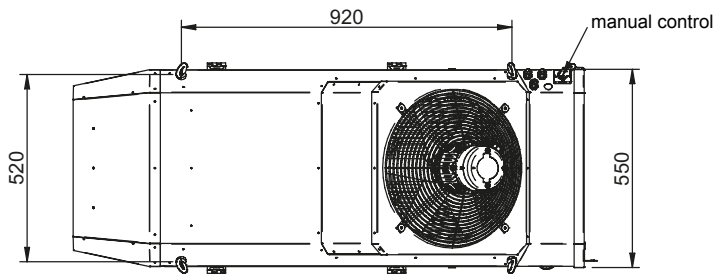

front view

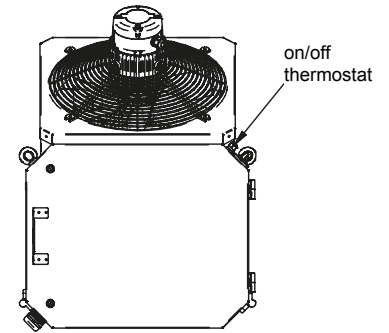

side view

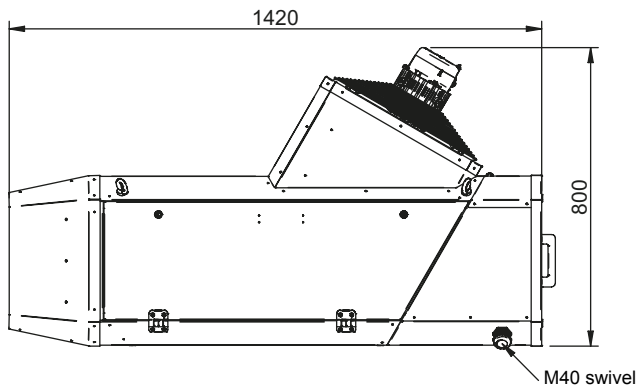

rear view

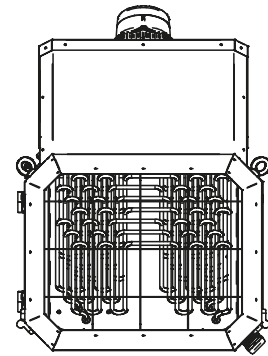

Technical data DX-EH

Type	Unit	DX-EH 40
Heating capacity high	kW	39,6
Heating capacity low	kW	19,8
Electrical connection	kW	40
Maximum electrical current per phase	A	59.0
Maximum air output (warm)	m ³ /h	3500
Horizontal throw (max)	m	40
Voltage (50 Hz)	V	400V+N
Length	mm	1400
Width	mm	550
Height	mm	795
Weight	kg	65
Sound level (@ 5 meter)	dB(A)	62
Supension/installation	suspended on wire or placed on a support	

DXC heaters

Winterwarm presents the DXC heater: an indirect gas fired heater with a closed combustion system especially designed for poultry houses. High energy prices and government policy force farmers to use efficient heating systems with low energy consumption. The DXC fully meets these requirements.

Indirect fired gas heater

The concept of the DXC intends to improve the durability in poultry farming. The energy consumption is reduced and the air quality is improved leading to lower energy costs and a better bird performance.

These positive results are realised because of the most important feature of the DXC: a closed combustion circuit. This means that the combustion air is taken from the outside, and the combustion gasses are transported back to the outside. As a result no CO₂ and no water vapor are brought into the poultry house. Consequently, the volume of the ventilation air can be

strongly reduced.

And less ventilation means less energy consumption. Calculations show that energy savings up to 25% per house per crop can be achieved!

Secondly, the closed combustion circuit also decreases the humidity level. This results in drier litter which is favourable for preventing typical diseases like pododermatitis, etc. The sickness rate decreases as does the mortality rate, so the output per bird flock increases.

Return on investment

In a poultry house equipped with DXC heaters the volume of the ventilated air can be much lower compared with conventional heating. This leads to considerable energy savings.

As the ventilation volume is reduced, also the total installed heating capacity can be lower compared with conventional systems. Although the initial investment for installing one DXC heater is higher, it has been calculated

that the return on investment rate lies between 2 to 3 years! (depending on national gas prices).

Safety and reliability

The technology of the DXC has already proven itself in the well-known industrial TR-heaters from Winterwarm, which are sold successfully all through Europe. With a closed combustion concept there is no open flame in the space which is safer. This also has a positive effect on the insurance costs!

As clean air is taken from the outside, the burning process is very stable. There is no risk of pollution of the burner head like in conventional gas heaters. The heater is provided with an automatic electronic ignition. A display on the heater gives feed-back on the status of the heater.

On the outside of the heater a ventilation switch is mounted with which the heater can be switched to ventilation mode.



Characteristics:

- Stainless tubular heat exchanger
- Stainless steel casing
- Closed combustion = no combustion gasses in the house
- Combustion air taken from outside through flexible duct system
- Zero CO₂ = less ventilation = less energy = less costs
- Low sound level
- Extensive control possibilities
- Reliable, well-proven technology
- CE-approved
- Easy to service

top view

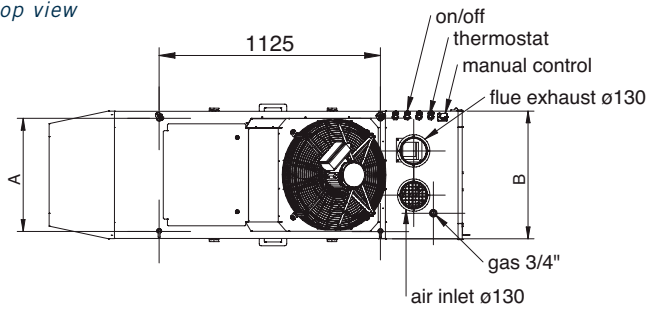

front view

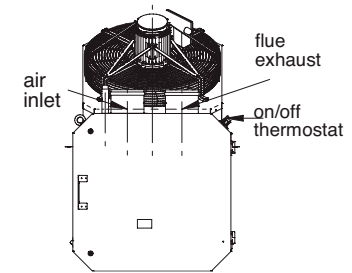

side view

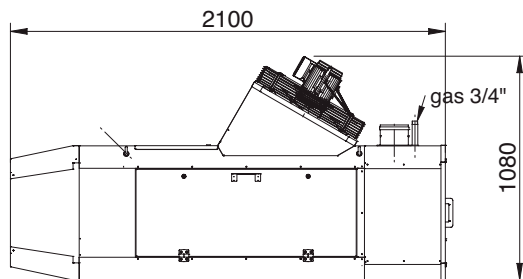

back view

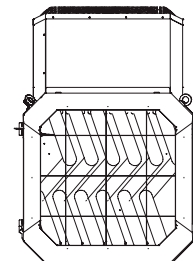

Type	A	B
DXC60/80	575	650
DXC100	740	815

The robust stainless steel housing of the DXC is especially engineered for application in poultry houses.

As a gas heater of course the DXC is CE-approved. Each heater is subjected to a final control test at the factory during which electrical safety, correct emission values and general operation are checked.

Also, Winterwarm is ISO 9001-2015 certified, therefore, the overall quality and safety is guaranteed.

Controls

The DXC has various control possibilities.



Modbus control set GA5903



0-10 V. input control set GA5906



Remote Status Reader GD3202



On/off thermostat IP794209



Interface Unit - IB5902

- Zone control for 1-8 heaters
- 0-10 V. analogue input
- Connection for burner on/off
- Connection for ventilation on/off
- Reset function
- Output failure signal
- Output "in operation" signal

Technical data DXC-series

Type	Unit	DXC 60	DXC 80	DXC 100
Nominal heat input	kW	65.5	83.0	108.0
Nominal heat output	kW	60	76	99
Efficiency maximum power	%	91.5	91.5	91.5
Air output	m ³ /h	6000	8000	10000
Throw	m	40	45	45
Electrical capacity	W	800	900	1400
Power consumption	A	3.5	3.9	6.1
Electrical connection	V	230	230	230
Maximum gas consumption G25	m ³ /h	7.8	9.9	12.8
Maximum gas consumption G20	m ³ /h	6.9	8.8	11.4
Maximum gas consumption G31	kg/h	5.2	6.6	8.6
Gas connection	G"	3/4	3/4	3/4
Noise level	dBA	68	68	68
Weight	kg	140	150	175
Flue diameters	mm	130	130	130

DXC heaters

Maintenance and service

The heatexchanger of the DXC is accessible for cleaning from 3 sides of the heater. The access is very easy by opening the side panels and the top panel. The distances between the tubes in the tubular heat exchanger are wide, and the round shape of the tubes results in a minimum of dust which can stick to the surface. During cleaning any remaining dust can simply be blown away. The body of the DXC is made from stainless steel which can resist high-pressure cleaning.

- 1 Flue terminal 130/210 mm
- 2 Flue mounting kit: 2x male and female adapters & 2x safety clamps
- 3 Flexible pipe & spacer bracket (1 per m.)

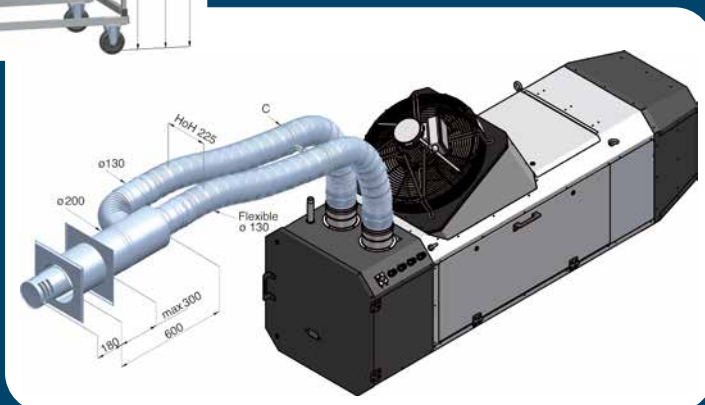
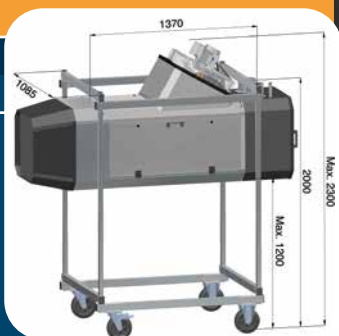
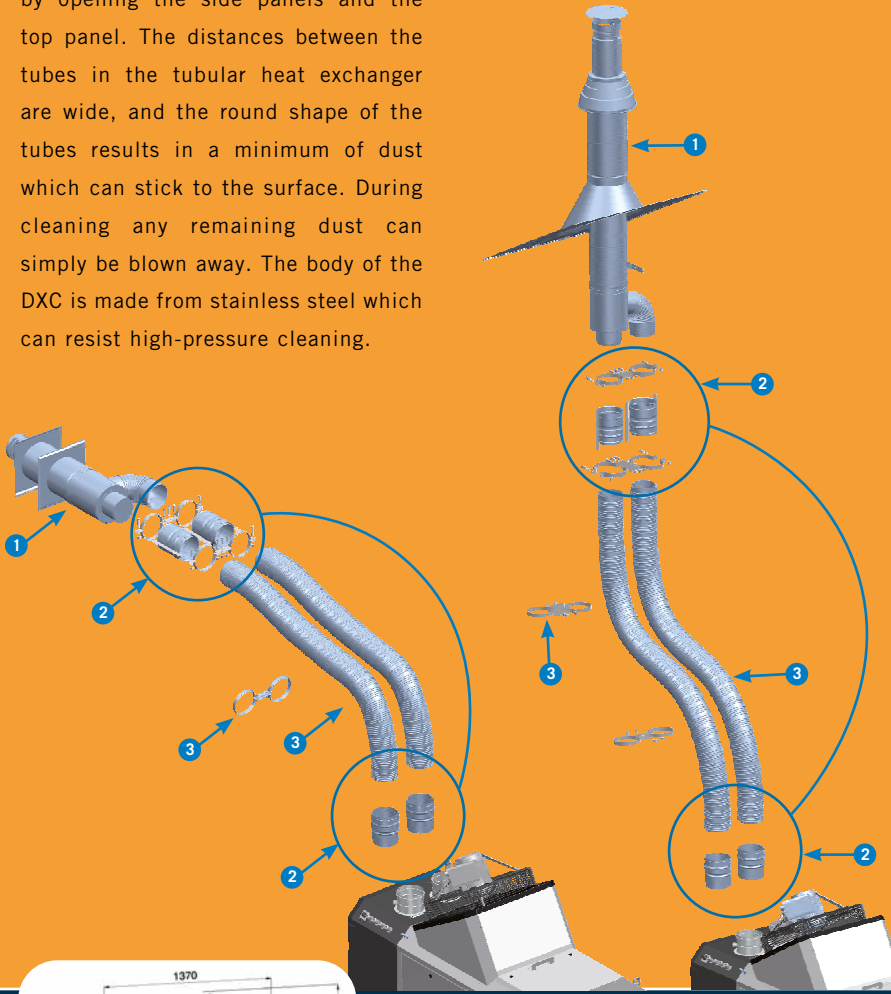

Accessories

When installing a heater with a closed combustion circuit, of course a fresh air inlet and a combustion outlet have to be installed. Winterwarm offers a complete range of flue terminals (vertical and horizontal) with flexible ducting, extension pipes and accessories.

The DXC is provided with 4 suspension screws which can be used to suspend the heater on chains.

As an accessory Winterwarm offers a mobile heater stand on which the DXC can be suspended.

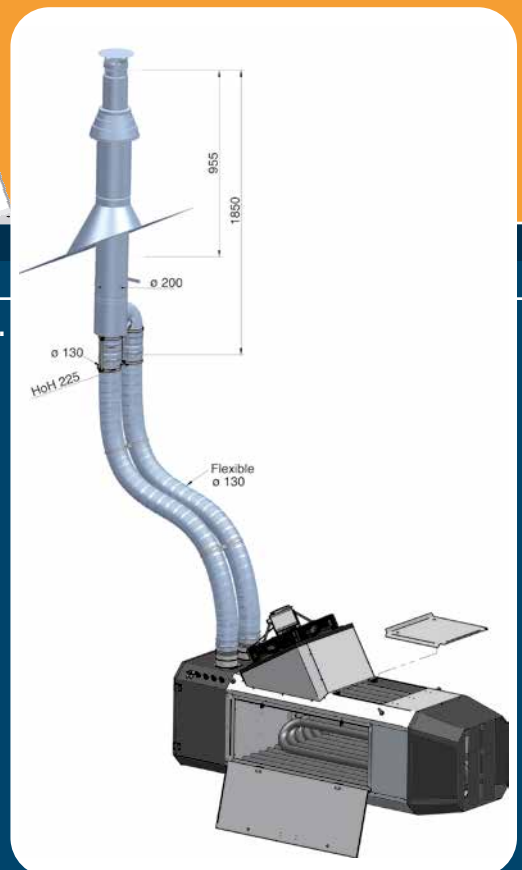



DXE heaters

The DXE is a unique heating concept for poultry houses as it combines the advantages of a closed combustion circuit with the advantage that the heater is installed outside the house.

Indirect fired gas heaters

The DXE is an indirect fired heater. This means that the combustion gasses remain outside the poultry house, eliminating the need to extract CO₂ and water vapour from inside. The ventilation volume is considerably reduced thus preventing the need to warm up large volumes of cold outside air, resulting in lower gas consumption. Research shows that energy savings of up to 25% are possible when compared to direct fired heaters.

Better bird performance

Due to the closed combustion circuit, the level of humidity is significantly reduced in comparison to a direct fired heat source. Humidity related diseases such as Podo etc. are favourably reduced as a result drier litter. Bird sickness and mortality rates are reduced, resulting in an improved yield. As outside air is used for the combustion, the DXE does not reduce the oxygen levels for the bird.

Bio security

One of the important features of the DXE is the installation being on the exterior of the poultry house, enabling easy access during a crop cycle for any necessary maintenance or repairs, thus eliminating a potential contamination source, Bio Security being even more imperative for the breeder grower. Removal or winching of heaters for cleaning is unnecessary as the heaters are installed in the side wall of the shed. There is a large hatch situated at the side of this heater where the heat exchanger and the fan can be cleaned in between crops.



Characteristics:

- Indirect fired gas heater
- Situated outside the poultry house
- High air output
- 100% circulation of return air
- No combustion gasses in the house
- No CO₂ in the house → less ventilation → less energy consumption
- Reliable burner technology
- Robust construction
- Extensive control possibilities
- CE-approved
- Easy to service which is carried out externally



Robust quality

The housing of the DXE is made from a specially coated steel which encapsulates insulation reducing heat loss. The burner technology originates from well established Winterwarm heaters. Risk of the burner head getting polluted is extremely low as clean outside air is used in the combustion process.

Controls

The DXE is provided with an on/off contact for simple control. Also the heater can operate in high/low modus (100%-60%) by means of an Interface Unit. This unit can be connected to a climate control system. With a 0-10 V. signal current functions like burner modulation, ventilation, operation signal, failure signalization and remote reset can be controled.

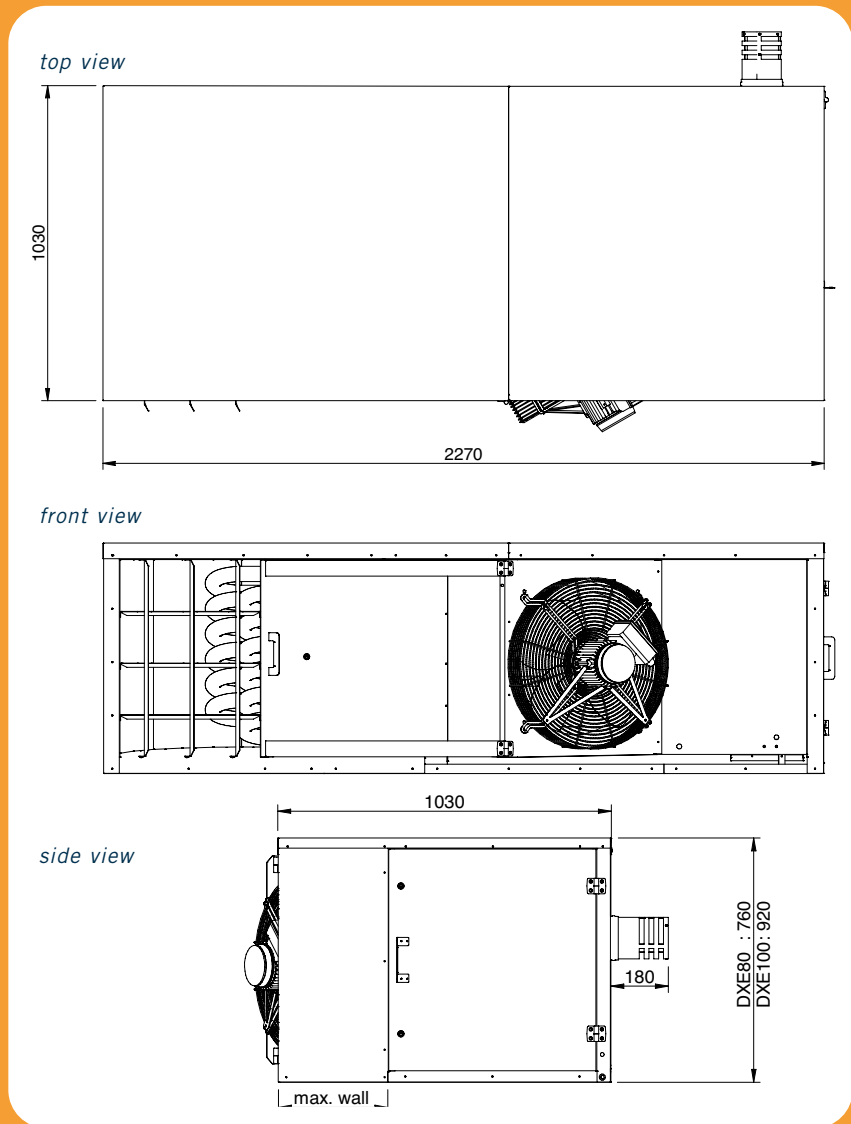

Furthermore a Remote Status reader is available to read out the various functions.

Technical data DXE-series

Type	Unit	DXE 80	DXE 100
Nominal heat input	kW	83	108
Nominal heat output	kW	76	99.1
Efficiency maximum power	%	91.5	91.8
Air output	m ³ /h	8000	10000
Throw	m	45	50
Electrical capacity	W	900	1400
Power consumption	A	3.9	6.1
Electrical connection	V	230	230
Maximum gas consumption G20	m ³ /h	8.8	11.4
Maximum gas consumption G31	kg/h	6.6	8.6
Gas connection	G"	3/4	3/4
Sound level	dB(A)	68	68
Weight	kg	150	175
Flue diameters	mm	130	130

DHX and DXB heaters

The DHX and the DXB series meet the demand in the agricultural and horticultural markets for durable and efficient heaters based on a well-known concept.

Direct fired heaters for gas and oil

A correct temperature and an even air distribution are important factors for the growing environment in both agriculture and horticulture. The DHX and DXB-series are especially designed to control these factors optimally. The large air flow capacity (4000 - 7000 m³/h) and the special round shape of the heaters ensure optimum air distribution, which guarantees an even heat distribution and consistent climate throughout.

The DHX and DXB heaters have a guaranteed efficiency of 100% as all generated heat is supplied directly into the room. The burner with its stabilized flame provides a clean, complete combustion in combination with a relatively low energy consumption. They are suitable for various types of fuels:

type DHX - natural gas (high- or low calorific value), butane, propane or LPG; type DXB - diesel or paraffin. The heaters are adjusted and tested for the right fuel type in the factory. For the DHX conversion kits are available to change the gas type on site.

Safety and reliability

Above all these heaters offer reliability. The gas fired DHX range is CE approved. All heaters are subject to a final test during which electrical safety, correct emission values and general operation are checked. The heater is provided with the latest technology for optimum control. The ignition process is fully controlled by a digital circuit board. In case of flame failure 3 automatic re-starts are carried out. The status of the heater can be monitored on the PCB-board in the control box. To minimise the risk on failures, the DHX and the DXB carry out a self-check each hour.

Maintenance and service

The DHX and the DXB are very robust heaters as they are completely manufactured from stainless steel. This characteristic ensures a long and maintenance free life cycle. The PCB control board and associated components are placed in a spray-proof box so that the heaters can easily be cleaned after each crop. The heater is developed in such a way that the susceptibility to interferences is limited to a minimum and that the safety is maximized in order to allow your animals or plants to grow without problems.



Controls

As standard the DHX and the DXB can be switched on by an on/off contact through a signal of the climate control system or a common room thermostat (low voltage current - connection for max. 8 heaters). The circuit board is provided with a facility to switch the DHX and DXB to ventilation position.

Options:

- Connection for external fans to switch simultaneously
- Interface Unit - connection to climate control system to be able to send and receive various signals
- Remote status reader.



Interface Unit - IB5902

- Zone control for 1-8 heaters
- 0-10 V. analogue input
- Connection for burner on/off
- Connection for ventilation on/off
- Reset function
- Output failure signal
- Output "in operation" signal

DHX heaters



Characteristics

- body from stainless steel • efficiency 100% • reliable • 1 automatic restart
- hourly self-check • possibility for ventilation position • high air output • CE-approved
- possibility to connect 8 heaters to 1 thermostat • easy to clean (IPX4B)  • RT-contact for control by a stable computer

DHX 40-75

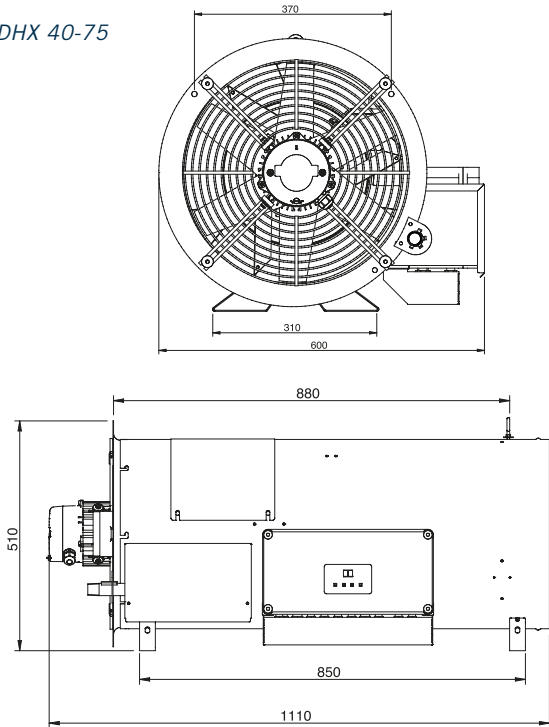

DHX 100-120

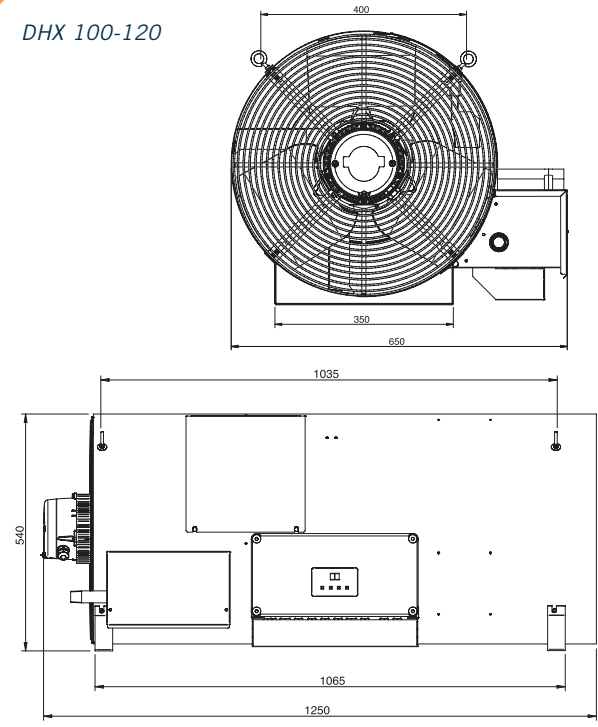

Technical data DHX-series

Type	Unit	DHX 40	DHX 75	DHX 100	DHX 120
Nominal heat input	kW	40	72	100	120
Heat output	kW	40	72	100	120
Air output (warm)	m ³ /h	3900	3900	5900	6800
Throw	m	43	43	51	51
Gas connection	G"	3/4"	3/4"	3/4"	3/4"
Voltage (50Hz)	V	230	230	230	230
Electrical power	kW	0,16	0,16	0,24	0,24
Electrical power (standby-modus)	W	4	4	4	4
Electrical current	A	1,0	1,0	1,6	1,6
Maximum gas consumption G25	m ³ /h	5,0	8,9	11,8	14,1
Maximum gas consumption G20	m ³ /h	4,2	7,5	10,3	12,3
Maximum gas consumption G30 (propane)	kg/h	3,8	5,7	7,9	9,5
Switch point pressure switch	mbar	15	15	15	15
Sound level (@ 8 meter)	dB(A)	65	65	70	70
Weight	kg	35	35	45	45

DXB heaters



Characteristics

- body from stainless steel
- efficiency 100%
- reliable
- 1 automatic restart
- hourly self-check
- possibility for ventilation position
- high air output
- possibility to connect 8 heaters to 1 thermostat
- easy to clean (IPX4B)



Remote Status Reader
GD3202



On/off thermostat
IP794209

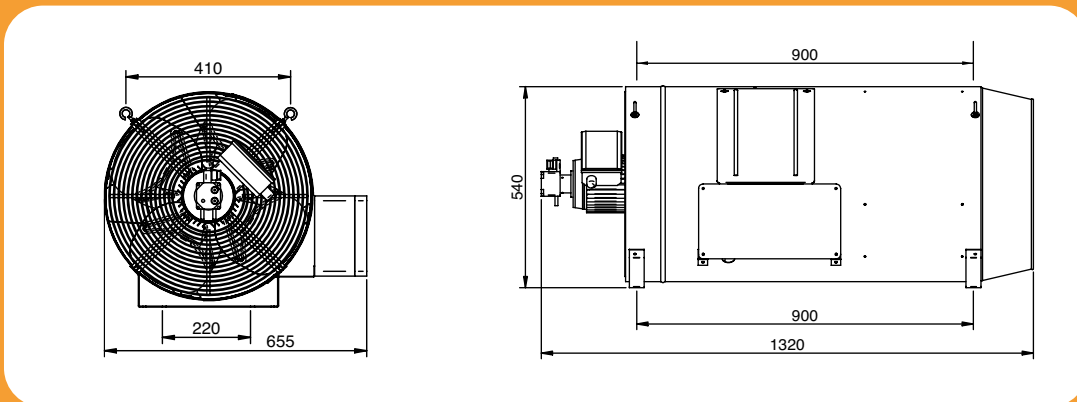

Technical data DXB-series

Type	Unit	DXB 100	DXB 120
Nominal heat input/output	kW	100	120
Air output (warm)	m ³ /h	6,000	7,000
Throw	m ³ /h	45	45
Electrical power	W	900	1000
Electrical current	A	4.6	4.8
Voltage (50Hz)*	V	230	230
Sound level	dB(A)	79	79
Weight	kg	45	45
Oil consumption parafin	l/h - kg/h	10.1-8.3	12.1-9.7
Oil consumption diesel	l/h - kg/h	9.8-8.3	11.7-10.0
Oil connection	mm	6	6

DX fan

An optimal growth climate is essential in poultry houses and greenhouses. Distribution fans provide an even distribution of the warm air, and therefore contribute considerably to a good climate in the house.

The Winterwarm DXF has a high air output. It contributes to a reduction of the energy consumption and improves the heat distribution in the stable or poultry house.

Less energy consumption

In order to realise a constant, controllable temperature in your poultry- or greenhouse, distribution fans are essential. Especially greenhouses can be very airtight nowadays. Less heaters are installed in order to decrease the energy consumption as much as possible. The fans then take care of an even distribution of the generated heat. Also condensation on the crops is reduced.

In poultry houses the same arguments are valid but there the installation

of the distribution fans is particularly advisable when DXC heaters are installed (see page 4). After all, in houses with DXC heaters less air is introduced (and lost again to the outside) but the heat present still has to be well distributed in the house in order to create an optimal climate for

the chickens. Applying DXF fans is an effective and financially attractive way to realise that.

As the purchase price of a DXF fan is relatively low, the return on investment period for these fans is fairly short. With continuously increasing energy prices the installation of distribution fans is financially becoming more interesting every day! But most important, they are vital for an optimal growth climate.



Characteristics DX fan:

- high air output (5000m³)
- energy-saving
- robust SS-body
- light and easy to install
- IP55
- air inlet/outlet opening 460

Technical data DX fan

Unit	DX fan	
Inlet side diameter	mm	460
Outlet side diameter	mm	460
Body length	mm	300
Air output	m ³ /h	5000
Throw	m	30
Mains voltage	V	230
	Hz	50/60
Electrical current	A	1.3
Electrical capacity	W	290
Maximum noise level at a 4m distance	dB(A)	68

Winterwarm: leading

Winterwarm has been engaged in the development, production and sales of industrial heating in Europe since 1936. The company not only specialises in hybrid heaters and indirect fired unit air heaters, but also sells water heaters, electric heaters, destratification fans and gas and oil fired heaters for the agricultural and horticultural industry.

Version: April 2024

Winterwarm 
heating solutions

Winterwarm Heating Solutions BV
Olden Goorweg 1 Winterswijk The Netherlands
P.O.Box 36 NL-7100 AA Winterswijk The Netherlands
Tel. +31 (0)543 54 63 00
www.winterwarm.com info@winterwarm.nl



European Association of
Air Heater Manufacturers

